

HC900 Hybrid Controller

Specification



Applications
Pump stations
Boilers
Water treatment
Pilot operations
Fermenters
Utility DAQ
Furnaces
Kilns
Autoclaves
Extruders
Reactors
Retorts
Sterilizers
Crystal Growing
Dryers

Overview

The Honeywell HC900 Hybrid Controller is an advanced loop and logic controller offering a modular design sized to satisfy the control and data management needs of a wide range of process equipment. When combined with the optional 1042 or 559 Operator Interfaces that are fully integrated into the controller's database, configuration and setup time is minimized. This powerful combination together with Honeywell's performance proven control technology provides users an ideal solution for process control. Open Ethernet connectivity with Modbus TCP Protocol also allows network access using a variety of HMI/SCADA software.

Easy-to-use Windows-based Hybrid Control Designer software, operable over Ethernet, an RS232 port or modem connection, simplifies controller and operator interface configuration. It provides advanced monitoring functions for debug, allows run-mode configuration changes while maintaining process control, uploads the complete, annotated graphic controller and operator interface configuration, plus supplies an array of reports for enhanced documentation.

The HC900 Controller provides superior PID loop control and more

robust analog processing than most logic controllers without compromising logic performance. A separate, fast scan cycle executes a rich assortment of logic and calculation function blocks. Logic blocks may also execute in the same scan with analog function blocks for time critical events. These function blocks may be fully integrated into a combined analog and logic control strategy for uncompromising control performance.

For more information see specification sheets:

- HC900 Hybrid Controller Modules 51-52-03-41
- Hybrid Control Designer Software 51-52-03-43
- 1042 & 559 Operator Interfaces 51-52-03-32.

Features Summary

- Non-redundant and Redundant Architectures
- PID Control with auto-tuning
- Up to 1920 points with remote I/O
- Boolean Logic programming
- Robust assortment of over 100 algorithms
- Advanced Floating Point Math Functions
- Extensive Alarm and Event Monitoring
- Up to 960 Isolated, Analog Inputs
- Remote I/O Racks
- I/O Insert/Remove under power
- LED on/off indicators on digital I/O
- Graphic Function Block Configuration – 400, 2000 or 5000 blocks
- Fast updates – 27 ms logic, 0.5 sec analog
- Open 10MB or 10/100MB Ethernet interface using Modbus/TCP
- Peer-to-peer communications via Ethernet
- E-mail alarm/event messaging on priority
- Stored recipes, SP profiles, sequences, schedules
- Ramp/Soak Setpoint Programmers
- Setpoint Schedulers with multiple outputs
- Sequencers with 16 Outputs each

Non-redundant Architectures

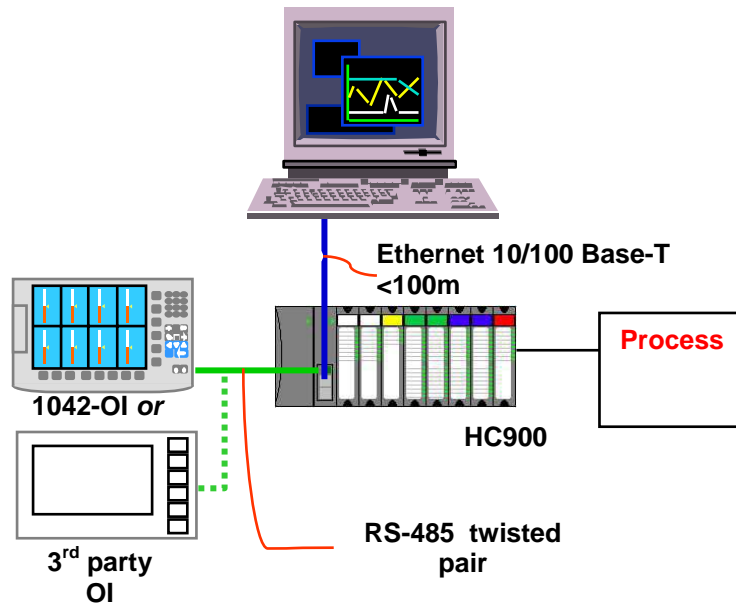

Single process/single rack

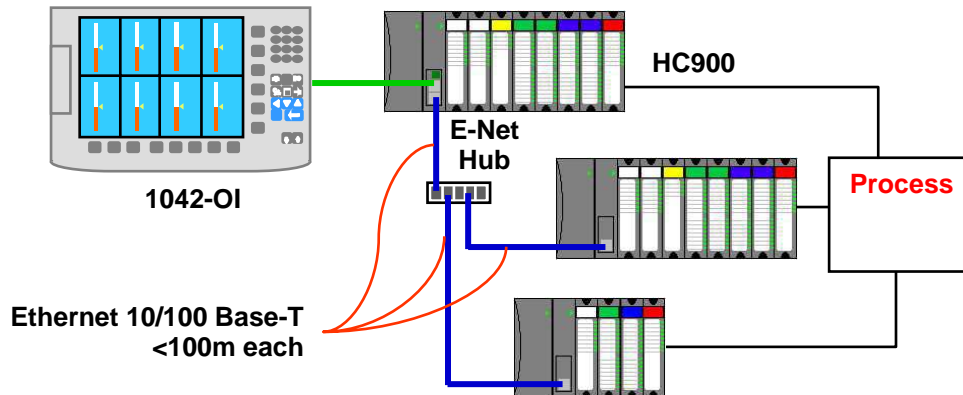

Single process/ multiple remote I/O Racks

Non-redundant Architectures

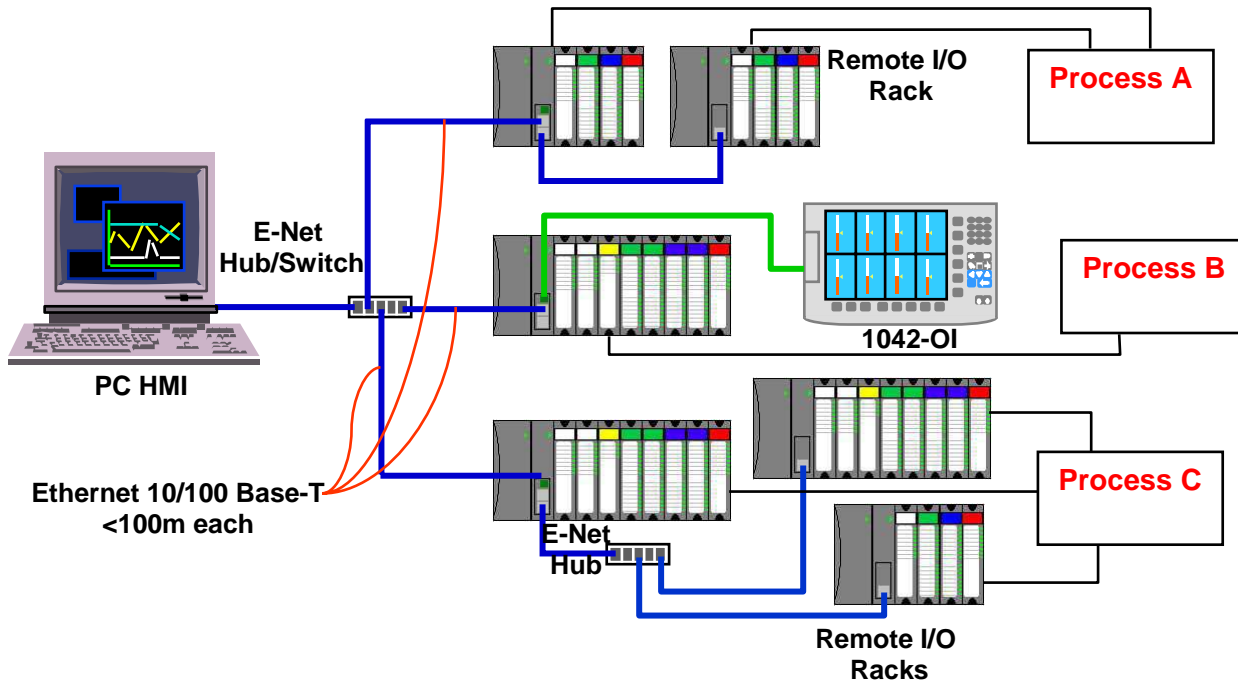

Multiple processes/multiple racks

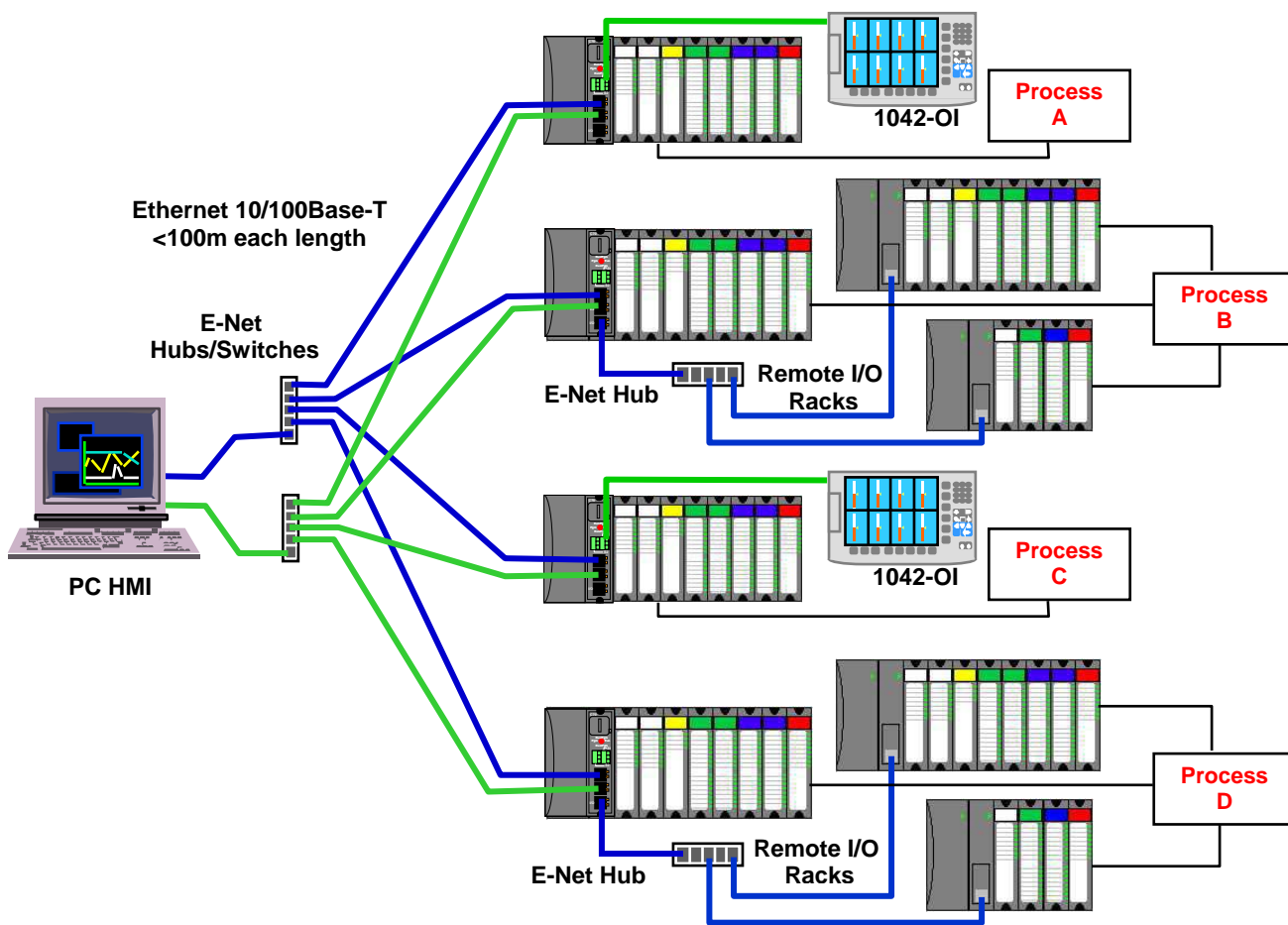

Multiple processes/multiple racks/C70 controller redundant networks

HC900 Controller

- The rack based HC900 Controller is available in 3 rack sizes with 4, 8 or 12 I/O slots each to support a wide range of requirements.
- Redundant C70R controllers use a separate controller rack for CPUs without local I/O. Two power supplies provide separate CPU power. A redundant controller switch module provides status and performs mode changes.

CPU Modules

- The CPU options available for the HC900 Controller include:
 - C30 and C50 for non-redundant applications.
 - C70 for redundant networking
 - C70R for redundant CPU applications and redundant networking.
- All HC900 CPU modules offer open Ethernet communications for access by a variety of HMI and SCADA software applications and peer to peer communications for control data exchanges between controllers. The C70 and C70R provide redundant Ethernet ports for high network availability installations.
- HC900 CPU modules use a dual scan method to handle fast digital scanning and normal analog input scanning in the same integrated control environment. Both scans support a wide range of computational function block algorithms and a user adjustable execution sequence order.
- HC900 CPUs use Flash memory for permanent user configuration program storage and battery-backed memory for dynamic data storage allowing for graceful recovery following a power interruption or other discontinuous operations.

I/O Scanners

HC900 Remote I/O is processed and communicated to the main CPU module through a remote I/O Scanner module. Two I/O scanner modules are available: a single port model for non-redundant CPU systems and a dual port model for redundant CPU systems. Scanner addressing in multi-rack systems is selectable via DIP switch setting.

Inputs and Outputs - A variety of I/O modules are available for selection in creating a custom control solution. These include:

- 8 point universal analog input modules: Inputs may be mixed on a module and may include multiple thermocouple types, RTDs, ohms, voltage or millivoltage types – all easily assigned using the Hybrid Control Designer configuration tool. High point-to-point isolation simplifies installation and saves the expense of external isolation hardware.
- 16 point high level analog input module: each point is configurable for V or mA. Point-to-point isolation.
- 4 point isolated analog output module: Supports from 0 to 20mA each.
- 16 point digital input modules: Contact closure type, DC voltage and AC voltage types.
- 32 point digital input module: DC voltage
- 8 point AC or 16 point DC digital output modules
- 32 point digital output: DC voltage
- 8 point relay output module: four form C type and four form A type relays.
- 4 channel Pulse/ Frequency/Quadrature I/O module

See Module Specification sheet 51-52-03-41 for details.

Insert & removal of I/O under power-

For ease of maintenance, the HC900 controller supports removing and inserting I/O modules from the card rack without removing power from the controller. Each card is sensed for validity by the controller and auto-configured on insertion.

I/O Terminal Blocks – 20-screw Terminal Blocks are available with either barrier style or Euro style screw connections. A module label area is provided for field wiring identification. An available 36-screw Euro Terminal block is required for certain high capacity modules.

Remote I/O - I/O racks may be remotely mounted from the controller via a dedicated Ethernet 10/100Base-T connection at up to 300 meters (984 feet) between the controller and the most remote rack using two Ethernet hubs.

Remote Terminal Panels - Optional DIN rail mounted Remote Terminal Panels (RTPs) are available for use with pre-wired cables to reduce installation time and labor expense. RTP types available: analog input, relay output, discrete input, discrete output, analog output. Three cable lengths are also available to match hardware to installation variations. See Module Specification sheet 51-52-03-41 for more details.

Redundant Power - A second (backup) power module may be added to each HC900 controller rack . An extended rack is available that expands the standard I/O rack to accommodate a second (redundant) power supply and power status module.

Table 1 CPU Capacities

Function	Point per Module	Max. for C30 CPU	Max. for C50 CPU	Max. for C70/C70R CPU
Analog In	Universal: 8 High level: 16	Universal: 96 High level: 192	Universal: 480 High level: 960	Universal: 480 High level: 960
Analog Out	4	40	200	200
Digital In	16 or 32	384	1920	1920
Digital Out	8 AC or 16 DC, 32	384	1920	1920
Function Blocks	n/a	400	2000	5000
PID Loops	n/a	8	32	32

Redundant Architectures

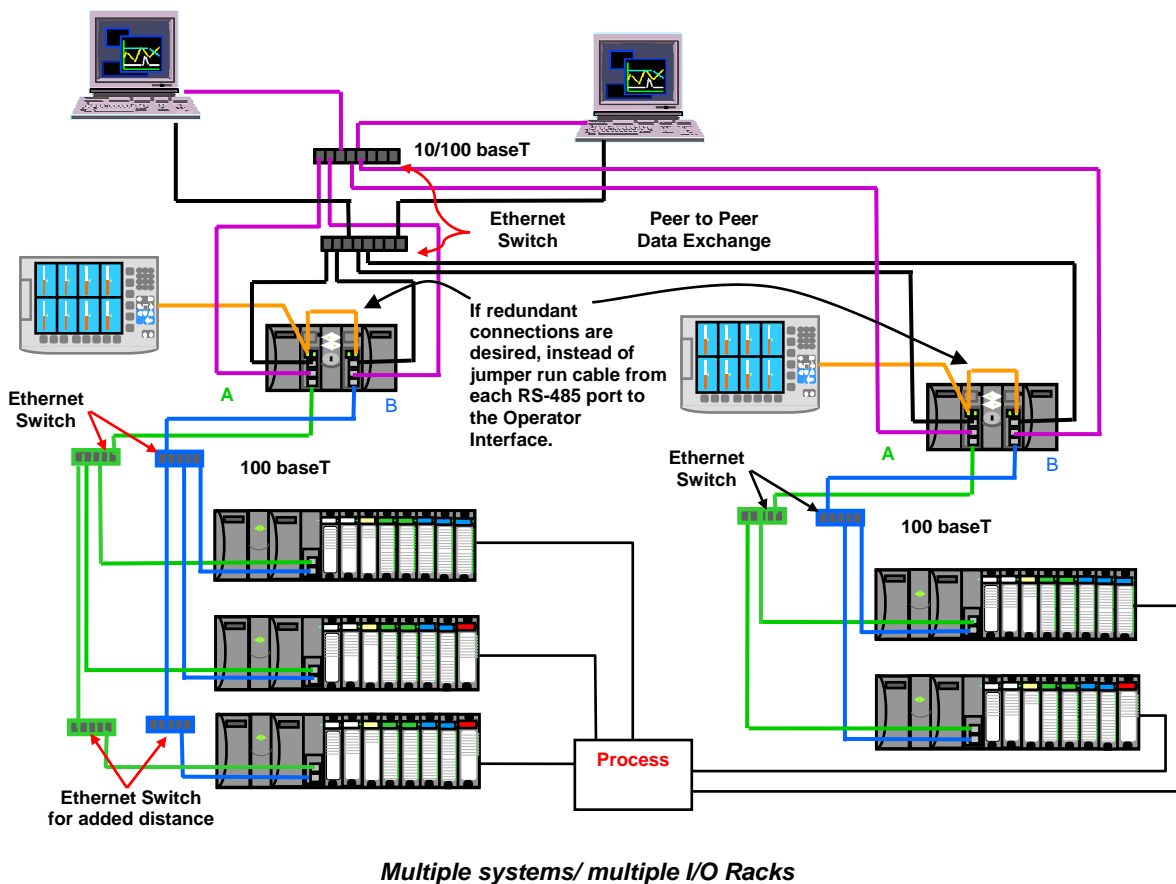
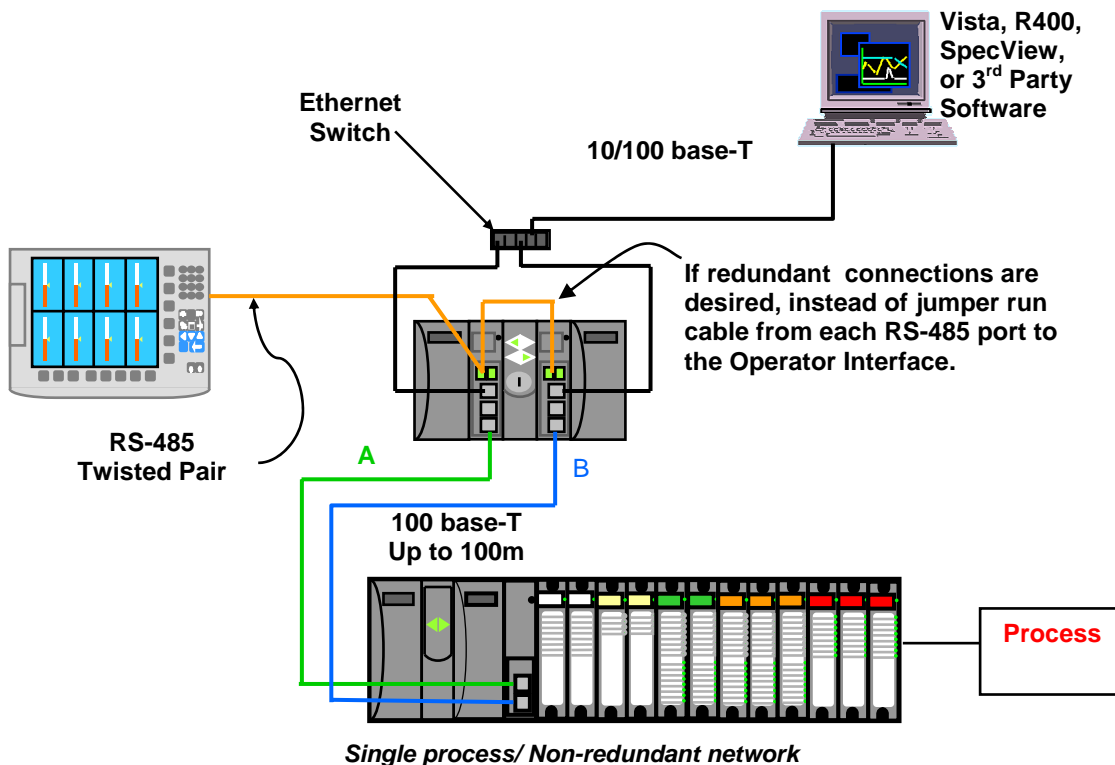

Redundant Architectures

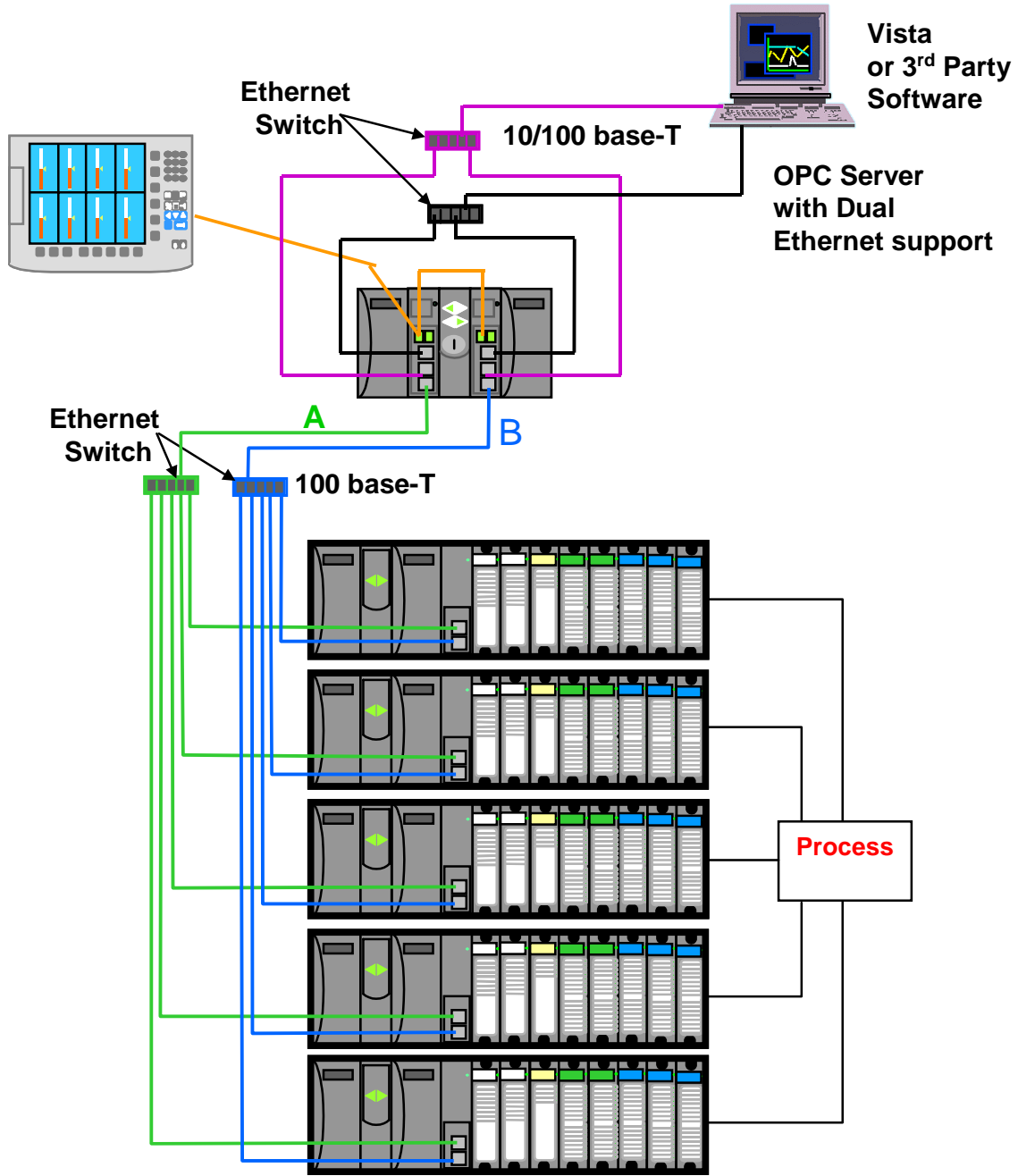

Single process, multiple I/O racks, redundant networks

Redundant Controller

Two redundant C70R CPUs operate in a separately mounted controller rack, each with an independent power supply. A Redundant Switch Module (RSM) is located in the rack between the two C70R CPUs. A key switch on the RSM allows the user to change the operating mode of the Lead CPU.

There is no I/O in the controller rack; the CPUs communicate with up to 5 racks of I/O over a 100 base-T Ethernet physical communication link. When more than one I/O rack is used in the system, Ethernet switching hubs are required, one for each Scanner connection. In operation, all control functions and host communication exchanges are handled by the Lead controller, including configuration and operator changes. The Lead controller updates the Reserve controller with all the information needed to assume control in the event of a fault condition. After power-up of the C70R CPUs, the first available CPU assumes the Lead function. The Lead may be transferred to the Reserve controller by:

- failure of the Lead controller,
- manually changing a keyed switch located on the Redundant Switch Module, or
- instruction from host communication.

Redundant Networks for Host communications are provided on the C70R CPU. Both network ports are continuously active on the Lead controller. An OPC server is available from Honeywell to support redundant Ethernet communications and automatically transfer communications. The C70R network ports may otherwise be used in non-redundant mode where only one of the communication ports is used.

Remote I/O - Up to two Ethernet switches may be used in each I/O connection to extend the distance between the CPU rack and the most distant I/O rack to 300m, 984 feet.

Operator Interface - 1042 and 559 series operator Interfaces are supported with the C70R CPU. The RS-485 serial connection is made to the serial communication ports of both CPUs. The operator interface communication to the controller follows the Lead controller assignment.

Status/Diagnostics - An output parameter of the system monitor function block of C70R CPUs provides a digital status of the Reserve controller to allow integration of this information into the control strategy. C70R CPUs also provide diagnostic status on redundancy operation that may be observed using Hybrid Control Designer configuration software. A Redundancy status function block is also available to monitor redundant controller operation.

Function Blocks

Advanced control and computational capability - A large assortment of analog and digital function blocks are available to solve the most demanding control requirements. Function blocks are grouped by scan rate, fast or normal, and by function, Principal or Standard.

Function Block execution - All function blocks operate synchronously with I/O processing. Inputs are measured at the start of every scan and outputs are updated at the end of every scan. Function blocks such as Time Proportioning Outputs (TPO) and Position Proportioning outputs (PPO) require higher output resolution and are updated when the function blocks are executing. Micro-controllers on digital I/O modules can maintain TPO duty cycle operation during failsafe conditions. Micro-controllers on all I/O modules allow outputs to be configured to assume a default state in the event of a fault condition.

Normal Scan: Function blocks that execute during the Normal Scan are synchronized to the analog input measurements. The fastest update rate is 500ms.

Fast Scan: The fastest update rate for fast scan function blocks in a single controller rack is 27ms. The update rate starts at 53ms when remote racks are used and for redundant systems.

Principal Function Blocks - These function blocks are supported by dedicated displays on 1042 and 559 series operator interfaces. They have Tag names and other attributes to support on-line user interaction. Typical Principal function blocks include PID, Set Point Programming, Sequencers, Alternators, Stage, etc.

Standard Function Blocks - The number of standard function blocks that may be used in a configuration is virtually unlimited. Typical Standard blocks include totalizers, free-form

math, average, mass flow, function generator, periodic timers based on real-time, carbon potential, RH, Dew Point, signal selection, comparison, and many others. These blocks may be configured to create control schemes that precisely address the needs of your process.

Digital status outputs are also provided on many of the analog function blocks to facilitate intelligent signal alarming and default operation strategies. Typical logic function blocks include AND, OR, XOR, NOT, Latch, Flip-flop, On/Off Delay and Resettable timers, Counters, Free-form Boolean logic and more. The execution of analog and digital functions is seamlessly integrated into a single control strategy in the controller.

Recipes

Recipes are groups of data defined by the user that are used to make multiple value changes in the controller through a single action. Function block types that accept recipe data and the quantity of recipes stored in the controller are listed in Table 2. Recipes may also include Variables, which are dynamic analog and digital values used as inputs to standard and principal function blocks. Recipes may be loaded through the 1024 and 559 operator interfaces by name or number, or via a dedicated recipe load function block and user configured logic.

Alarms/Events

Alarms and events represent changes in digital status that require user notification. The HC900 controller supports an internal alarm annunciation system that may be setup to operate with 1042 and 559 operator interfaces or via e-mail to a remote computer (see Communications, E-mail Alarming). Up to 240 alarm points per controller may be grouped in 20 groups of 12.

Events are digital status changes that cause messages to be presented on 1042 and 559 operator interfaces. They may prompt e-mail messages, do not require acknowledgement, and are reported and logged in a separate group. Up to 64 event points are supported in a controller.

Alarms and events are time stamped in the controller to a one second resolution.

Table 2 Recipe capacities

Function	Description	Content	Recipe size	# of recipes stored
Setpoint Programs	Profiles	Ramp/Soak values, times and event actions	50 Segments	99
Setpoint Schedules	Schedules	Ramp/Soak values, times and event actions	50 Segments	20
Sequencer	Sequences	State sequence, analog values	64 steps	10
Variable	Recipe Variables	Analog and digital values	50 Variables	99

Configuration

Controller configuration is performed using Hybrid Control Designer Configuration software on a PC operating with a Microsoft Windows® operating system. Configuration files may be built independently on the PC and downloaded to the controller in a separate operation. Validation of proper physical I/O to support the configuration is provided along with appropriate warnings.

Configuration Back-build - In the event a PC configuration file is lost or misplaced, it can be easily reconstructed using the upload function of the Hybrid Control Designer configuration software. Simply read the configuration from the controller to exactly duplicate the original configuration, including all text descriptions and operator interface display selections.

Configuration edit - In the event edits to a controller's configuration are required after the unit is in operation, an uploaded file may be monitored during process operation, edited, and downloaded with the on-line download function of the HC900 Hybrid Control Designer. The software allows configuration changes while in the Run mode, limiting process disturbances.

Operator Interfaces

HC900 system supports a choice of two operator interfaces that are integrated into the database configuration of the controller. The model 1042 provides a 10-inch color display and the model 559 offers a 5-inch color display. The full configuration of these operator interfaces is stored in the database of the controller and loaded into the interface on power-up. See specification sheet 51-52-03-32 for more information on these interfaces.

Communications

Remote I/O Rack Port (C50, C70, C70R) – An Ethernet port is dedicated to supporting remote I/O racks. This 10/100Base-T

connection on the C50 and C70 CPU supports a single direct connected remote rack or up to 4 remote racks when connected through an external Ethernet switching hub. The C70R CPU supports a single direct connected rack or up to 5 remote racks using external switching hubs.

User Interface Support – An RS 485 port provides communications between the controller and a 1042 or 559 Operator Interface. This port supports a single Operator Interface for distances up to 2000 feet (609 meters) between the controller and operator interface. The Honeywell Operator Interface configuration is stored in the controller CPU and is loaded into the operator interface on startup.

3rd party user Interface support is provided through RS232 and/or RS485 port connections using Modbus/RTU protocol, or Ethernet with Modbus/TCP protocol.

Ethernet Communications –HC900 controllers communicate with their host PC interfaces over an Ethernet 10/100Base-T communication network using the Modbus/TCP protocol, an open protocol interface available for most popular HMI software packages. The C30/C50 support up to 5 host connections while the C70/C70R supports up to 10 host connections concurrently. over an Ethernet network for control supervision and data acquisition. The Hybrid Control Designer software can also address any of the controllers concurrently over Ethernet for configuration monitoring, diagnostic interrogation, upload/download, or on-line configuration changes. As a result, a HC900 network of controllers and operator interfaces can be partitioned into process segments to assure proper control performance. Each of these process segments, in turn, can be accessed via common HMI software within the plant environment using an Ethernet LAN.

Ethernet Peer to Peer Communications - Peer data communications between one HC900 controller and up to 8 other HC900 controllers is supported over Ethernet via UDP protocol for process interlocks or data sharing. Both digital and analog data exchange are supported using peer data exchange function blocks, up

to 1024 parameters between peer controllers. No specialized software is required. Peer data can be given signal tag references for use in a control or data acquisition strategy. Peer to peer data interchange does not consume one of the host connections.

Serial Modbus RTU Communications - Serial Modbus RTU communications is available on the RS232 and RS485 (2 wire) ports of the HC900 Controller CPU assembly in a Master or Slave mode. The protocol of these ports is user selectable between ELN protocol for use with HC Designer software and Honeywell operator interfaces, or Serial Modbus to interface with other compatible devices.

Modbus RTU Slave - The RS232 and RS485 ports may be configured for simultaneous operation as a Modbus slave port to allow each to communicate with a single Modbus master. The Modbus protocol supports read and write access to variety of controller parameters using predefined address locations. In addition, a 1000 register array is available to allow the user to specify the address locations of specific controller data to optimize controller communications. The data in the array may also be accessed in user specified formats (data types) such as analog data in Float 32, unsigned 16, signed 16, unsigned 32, signed 32, and digital data in signed 16 or unsigned 16. The data type selections in the 1000 register array provide compatibility with devices such as 3rd party touch panels.

Modbus RTU Master - Either of the ports may be configured as a Modbus RTU master, one per controller. Up to 16 devices may be multi-dropped on the RS485 port or the RS232 port with an external, user supplied, RS232 to RS485 converter. Function blocks are available in the HC900 controller to allow the user to specify read and write operations to up to 16 external Modbus compatible slave devices and up to 384 data points. For C30 and C50 only: if the RS485 port is configured for Modbus RTU communications, a local 559 or 1042 operator interface will not be available.

Communications (cont'd)

E-mail Alarms/Events--HC900 alarms or events can be individually configured to send an e-mail alarm (or event) message to e-mail addresses with the assigned alarm priority.

- Number of e-mail addresses: 3 based on alarm priority
- From: Controller name (up to 16 characters)
- Subject: text (up to 32 characters)
- Content: date and time of alarm/event, alarm/event tag name, alarm/event state
- Message: 48 character text (for alarms only)
- Priority Levels: 4 for alarms, 1 for events

Controller Configuration Access – HC Designer software supports communicating with HC900 controllers using an Ethernet or serial connection using ELN protocol to support direct PC connection for configuration upload, download, debug and maintenance. Modbus RTU protocol is also supported through the serial port interface. Once the HC900 controller has been configured using Hybrid Control Designer Software, on-line configuration changes may be made while maintaining process control.

Configurations may also be loaded into the controller via the Ethernet TCP/IP network from a host PC. On-line monitoring for program debug and on-line program edit functions are also supported via the Ethernet port.

Modem Access--Communications to the HC900 controller may be via an external modem connected to the controller's RS232 port. HC Designer software supports configuration upload, download and on-line edits via modem. When modem communication is selected, Modbus RTU communication timeouts are extended.

Vista Supervisory Software--Honeywell's Windows 2000 version is available when PC-based supervisory control and data acquisition is required. Ethernet network interface to a Vista server is via the controller host Ethernet 100 Base-T port using Modbus/TCP protocol. Client Stations over Ethernet allow multiple user access to an HC900 network. Using the large selection of standard

operating display templates in Vista saves development time. When further customization is needed, the full graphic display development environment of Vista may be used to fully animate your process supervisory displays.

A batch reporting option is offered in Release 400 which enables batch reports to be created using a standard template. User-entered lot data is supported and up to 50 parameters can be defined for batch logging. The file can be exported in .csv format using a lot number-encoded filename.

SpecView32 Supervisory Software--SpecView32 software can be used as a supervisory interface for thermal-based applications, offering historical trending, batch reporting, recipe development involving setpoint programs and simplified graphics configuration. HC900 parameters are simply selected from categorized lists for placement on user-configured displays or onto display objects.

Network connection is via the controller host Ethernet 10/100Base-T port using Modbus/TCP protocol. A variety of Windows operating environments are supported including Windows 98, NT, 2000, and XP.

OPC Server--Network communication access to HC900 controllers through third party PC interfaces is simplified with Honeywell's OPC server software program. This software supports the Modbus/TCP interface to either redundant or non-redundant HC900 controllers. In redundant applications, Honeywell's OPC Server software supports dual redundant Ethernet connections to both C70R CPUs. Communications to the controller is maintained during a single network failure and/or following the transfer of the Lead function from one CPU to another. Compatible OPC client programs can use the Ethernet connection to the HC900 via Honeywell's OPC Server for remote supervision, data collection or other supervisory functions.

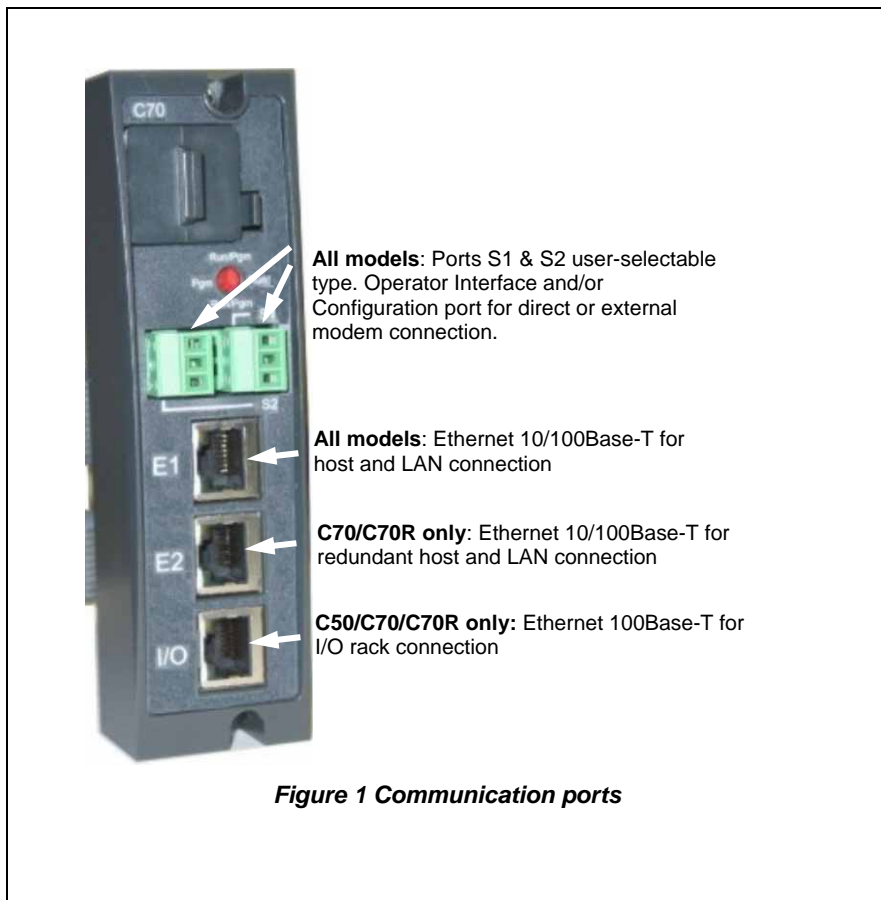

Figure 1 Communication ports

Specifications

	C30	C50	C70	C70R
Controller Design	Modular design with metal rack enclosure, power supply, controller CPU and user selectable I/O module types.			
Rack Mounting and Installation	Surface mounting with 4 screws in back of rack. Installation Category II, Pollution Degree 2, IEC 664, UL840 Installation coordination			
Controller I/O support	4, 8, or 12 I/O slots per Rack			None (requires remote I/O racks)
Remote I/O racks	1 w/o hub, using Ethernet direct cable. Up to 4 with recommended Ethernet hub(s).			1 w/o hub, using Ethernet direct cable. Up to 5 with recommended Ethernet switching hub(s).
Remote I/O interface type	None	Separate Ethernet 100Base-T port on CPU, RJ-45 connection, dedicated communications link		
Remote I/O Distance	None	328 ft. (100 m.) – controller to remote rack or controller to hub. Up to two hubs per connection, 984 ft. (300 m.), maximum distance.		
I/O Capacity				
Combined Analog and Digital	384	1920		
Analog Inputs	192	960		
Analog Outputs	40	200		
Rack Size				
4 I/O slot chassis	5.4"(137mm) H" x 10.5"(266.7mm) W x 6" (151.7 mm) D (rear mounting plate extends height to 6.9" (175.3mm))			
8 I/O slot chassis	5.4"(137mm) H x 16.5"(419.1mm) W x 6" (151.7mm) D (rear mounting plate extends height to 6.9" (175.3mm))			
8 I/O slot chassis with redundant power support	5.4"(137mm) H x 20.9"(530.9.1mm) W x 6" (151.7mm) D (rear mounting plate extends height to 6.9" (175.3mm))			
12 I/O slot chassis	5.4"(137mm) H x 22.5"(571.5mm) W x 6."(151.7mm) D (rear mounting plate extends height to 6.9" (175.3mm))			
12 I/O slot chassis with redundant power support	5.4"(137mm) H x 26.9"(683.3mm) W x 6."(151.7mm) D (rear mounting plate extends height to 6.9" (175.3mm))			
Redundant CPU rack	N/A			5.4"(137mm) H x 10.3"(261.6mm) W x 6" (151.7mm) D (rear mounting plate extends height to 6.9" (175.3mm))
I/O Wiring				
Type	Removable terminal blocks			
Terminal Block Styles	20 screw: Barrier or Euro-style, tin-plated or gold-plated (for DC connections) 36 screw: Euro style gold plated (Req'd with certain higher capacity modules)			
Gauge wires	20 screw: Barrier style – #14 to 26 AWG, solid or stranded Euro-style - #14 to 26 AWG, solid or stranded 36-screw: Euro-style - #12 to 26 AWG, solid or stranded			
Shield terminals	Optional brackets mounted top/bottom of rack			
Power (P01)				
Voltage	Universal power, 90 to 264VAC, 47 to 63 Hz			
In Rush Current	7 Amps peak-to-peak for 150 ms at 240VAC			
Input rating	130 VA			
Output rating	60W			
Fuse	Internal non-replaceable fuse. User installed external fuse.			

Specifications				
	C30	C50	C70	C70R
Power (P02) Voltage In Rush Current Input rating Output rating Fuse	Universal power, 90 to 264VAC, 47 to 63 Hz			
	7 Amps peak-to-peak for 120 ms at 240VAC			
	90 VA			
	28W			
	Internal non-replaceable fuse. User installed external fuse.			
Power (P24) Voltage In Rush Current Input rating Output rating Fuse	21 to 29VDC			
	30A for 3ms @29VDC			
	72.5W			
	60W			
	Internal non-replaceable fuse. User installed external fuse.			
Normal Scan Time	500ms. Each analog input card has its own A/D converter providing parallel processing.			
Fast Scan Time	53ms for up to ~250 fast logic blocks 67ms for up to ~315 fast logic blocks 107ms for up to ~400 fast logic blocks	27ms for up to ~250 fast logic blocks 53ms for up to ~500 fast logic blocks 67ms for up to ~780 fast logic blocks 107ms for up to ~1040 fast logic blocks 133ms for up to ~1300 fast logic blocks	27ms for up to ~300 fast logic blocks 53ms for up to ~600 fast logic blocks 67ms for up to ~950 fast logic blocks 107ms for up to ~1300 fast logic blocks 133ms for up to ~1600 fast logic blocks 267ms for up to ~3100 fast logic blocks	53ms for up to ~500 fast logic blocks 67ms for up to ~780 fast logic blocks 107ms for up to ~1040 fast logic blocks 133ms for up to ~1300 fast logic blocks 267ms for up to ~2500 fast logic blocks
Detection+Failover time from Lead to Reserve CPU	N/a		Up to 4 analog scan cycles	
Run-Mode Edit Transfer Time	3 normal scan times (1.5 sec. typical) for all configuration edits not applicable to I/O			
Operating Modes	Run (No configuration download in this position) Run/Program (Download allowed) Program (Outputs Off, initialization on download). Offline mode is available via software selection (for AI calibration).			

Specifications				
Features				
	C30	C50	C70	C70R
Maximum user-configurable Function Blocks	400	2000	5000	
Maximum Control Loops	8	32		
System Blocks (Not user configurable)	100 (not part of 400, 2000 or 5000), for Alarm Group blocks, System block, Rack Monitor blocks, Communications			
Loop Outputs	Current, time proportional, position proportional, 3-position step (motor positioning), dual output [heat/cool]			
Control Loop Types	PID A, PID B, Duplex A, Duplex B, Ratio, Cascade, % Carbon, Dewpoint, Relative Humidity, On-Off, Auto/Manual-Bias			
Auto-tuning	Accutune II, fuzzy logic overshoot suppression, applicable to all control loops			
Setpoint Programmers	8 (independent programmers) Ramp Types: Ramp Rate or Ramp Time Time Units: Hours or Minutes Segment Time: 0-99,999.999 hours or minutes Program Cycles: Up to 100 or infinite, configurable segment range			
Programmer Events	16, assignable to DO or internal status			

Specifications

Features				
	C30	C50	C70	C70R
Setpoint Profiles	99 profiles of 50 segments each stored in controller			
Setpoint Scheduler	Two (2) Ramp type: Ramp time Time units: Hours or minutes Segment time: 0.001 to 9999.999 hours or minutes Cycles: Per segment to 999 or infinite			
Auxiliary Scheduler Setpoints	Up to 8 setpoints, soak only			
Schedule events	Up to 16, assignable to DO or internal status			
Setpoint Scheduler Schedules	20 Schedules stored in controller, 50 segments each			
Sequencers	Four (4) States: 50 State text: 12 characters Steps: 64 Time Units: Minutes or Seconds Digital Outputs: 16 Analog Output: 1, configurable value/step Step Execution: On Time, Event 1, Event2, or via Advance Next Step: Any step			
Sequences	20 sequences stored in controller			
Recipes (Variables)	50 stored in controller			
Recipe Parameters	Up to 50 analog or digital Variables — (may include profile numbers)			
Signal Tags (Read only)	2000 Tags			
Tag Identification	8-character tagname, 16-character descriptor, 4-character units of measure (analog only), 6 character on/off state (digital only)			
Variables (Read/Write)	600			
Variable Identification	8-character tagname, 16-character descriptor, 4-character units of measure (analog only), 6 character on/off state (digital only)			

Specifications

Communications				
	C30	C50	C70	C70R
Network Communications Ports				
Number of Ethernet 10/100Base-T connections	1	1	2	2
Ethernet 10/100Base-T, RJ-45 connection	Supports Modbus/TCP Protocol to PC supervisory and data acquisition software packages, OPC server, and Hybrid Control Designer configuration software		Supports redundant Modbus/TCP Protocol to PC supervisory and data acquisition software packages, OPC server, and Hybrid Control Designer configuration software	
Max. number of concurrent Ethernet host connections	Up to 5 (peer data exchange does not consume a host connection)		Up to 10 shared between two ports (peer data exchange does not consume a host connection).	

Specifications

Communications				
	C30	C50	C70	C70R
RS-232 Ports	Two, user selectable between RS 232 and RS-485 with Modbus RTU or Honeywell protocol. 3-Plug connectors supplied.			
Ports per controller	Two, user selectable between RS 232 and RS-485 with Modbus RTU or Honeywell protocol. 3-Plug connectors supplied.			
Baud rates	9600, 19.2K, 38.4K, 57.6 K, configured by Hybrid Control Designer software or OI.			
Modem	For remote connection to Hybrid Control Designer software, requires external modem at controller, 9600 baud to 57.6KB			
RS-485 Ports	Two, user selectable between RS-485 and RS-232 (connector supplied), Honeywell or Modbus RTU protocol. Only one port for 1042/ 559 operator interface support.			
Ports per controller	Two, user selectable between RS-485 and RS-232 (connector supplied), Honeywell or Modbus RTU protocol. Only one port for 1042/ 559 operator interface support.			
Cable type	2-wire plus shield, Belden 9271 or equivalent			
1042, 559 Distance from controller	2000 ft. (600 m.)			
1042, 559 Power to OI	24VDC, user-provided at OI			
Unit addresses	1 to 247			
RS-232, RS-485 Ports	Odd, even, none			
Parity (user selectable)	Odd, even, none			
Stop bits (user selectable)	1 or 2			
Speed (user selectable)	9600, 19200, 38400, 57600			
Double Register Format for Modbus RTU Slave and Master data (User selectable)	Selectable byte order			
RS-232, RS-485 Modbus Slave Operation	Up to two			
Number of ports per controller	Up to two			
Masters per port	One			
User Specified Register Address Array	1000 register addresses (45057 to 46056 decimal)			
Principal Function Block Address Range	Data Types; Unsigned 16, Signed 16, Unsigned 32, Signed 32, Float 32			
	User selectable starting address range for registers assigned to each principal block type.			
RS-232, RS-485 Modbus Master Operation	One (RS232 or RS485)			
Number of ports per controller	One (RS232 or RS485)			
Function Block Types	Slave – 4 read and 4 write data points Read (Slave extension block) up to 16 parameters Write (Slave extension) up to 8 parameters (No limit on the number of Read and Write extension blocks per Slave block up to the maximum 384 parameters per controller.)			
Slave devices per controller	Up to 16			
Number of read/write Modbus Parameters	Up to 384 max. per controller			
Double Register Format	Selectable per device			
Speed	1 second fastest – load dependent			
Peer-to-peer	Supports UDP protocol and Peer Data Exchange function blocks for peer data exchange			
10/100Base-T via Network port	Supports UDP protocol and Peer Data Exchange function blocks for peer data exchange			
No. of Peers/Controller	8			
Update rate	500 ms to 5 sec., selectable			
Peer Data	Digital and Analog Signal Tags, Variables - up to 1024 parameters			
Ethernet	10/100 Base-T, RJ-45			
Ethernet Network Connection	10/100 Base-T, RJ-45			
Host Network Protocol	Modbus/TCP			

Maximum distances per Ethernet specifications		
Controller rack to I/O Rack	Ethernet CAT5 cable with RJ-45 connectors	100m /328 ft
Controller to Ethernet Switch	Ethernet CAT5 cable with RJ-45 connectors	100m /328 ft
Ethernet Switch to I/O Rack	Ethernet CAT5 cable with RJ-45 connectors	100m /328 ft
Controller to Network Switch	Ethernet CAT5 cable with RJ-45 connectors	100m /328 ft
Network Switch to PC	Ethernet CAT5 cable with RJ-45 connectors	100m /328 ft
Controller to 1042 Operator Interface	Shielded, Twisted pair	610m /2000 ft

Approvals				
CE Conformity	This product is in conformity with the protection requirements of the following European Council Directives: 73/23/EEC , the Low Voltage Directive, and 89/336/EEC , the EMC Directive. Conformity of this product with any other "CE Mark" Directive(s) shall not be assumed. EN61326: Electrical Equipment For Measurement, Control and Laboratory use. EMC requirements.			
General Purpose Safety	Compliant with EN61010-1, UL, UL 3121-1, CSA C22.2 No. 1010-1			
Hazardous (Classified) Location Safety	FM Class I, Div. 2, Groups A, B, C, D CSA Class I, Div. 2 Groups A, B, C, D Class 1, Zone 2, IIC			
Module "T" ratings	Module Type	"T" Rating	Module Type	"T" Rating
	Redundant CPU Rack	T6	Scanner 1 Port	T6
	Redundant PS Ext. Rack	T6	Scanner 2 Port	T6
	8 Slot Redundant PS Ext. Rack	T6	Analog Input (8 chan)	T6
	12 Slot Redundant PS Ext. Rack	T6	Analog Input (16 chan)	T6
	4 I/O Slot Rack	T6	Analog Output (4 chan)	T4
	8 I/O Slot Rack	T6	Digital Input, Contact type (16 chan)	T5
	12 I/O Slot Rack	T6	Digital Input, 24 Vdc (16 chan)	T4
	Power Supply (P01)	T4	Digital Input, 120/240 Vac (8 chan)	T3C @ Ta= 60 deg. C T4 @ Ta= 40 deg. C
	Power Supply (P02)	T4	Digital Input Vdc (32 chan)	T5
	Power Supply (P24)	T4	Digital Output, Relay type (8 chan)	T5
	Power Status Module (PSM)	T6	Digital Output, 24 Vdc, (16 chan)	T4
	C30/C50/C70/C70R CPU	T5	Digital Output, 120/240 Vac (16 chan)	T4
	Redundancy Switch Module (RSM)	T6	Digital Output Vdc (32 chan)	T6
			Pulse/Frequency/Quadrature (4 chan)	T5

Specifications

Environmental Conditions				
	Reference	Rated	Extreme	Transportation & Storage
Ambient Temperature				
F	77+/-5	32 to 140	32 to 140	-40 to 158
C	25+/-3	0 to 60	0 to 60	-40 to 70
Ambient Relative Humidity	*45 % to 55 % RH non-condensing	*10% to 90 % RH non-condensing	*5 % to 90 % RH non-condensing	*5 % to 95 % RH non-condensing
Mechanical Acceleration	0 g	1 g	1 g	Not rated
Duration	0 ms	30 ms	30 ms	
Vibration	0 Hz 0 g	0 Hz to 14 Hz— amplitude 2.5 mm (peak-to-peak) 14 Hz to 250 Hz— acceleration 1 g	0 Hz to 14 Hz— amplitude 2.5 mm (peak-to-peak) 14 Hz to 250 Hz— acceleration 1 g	
* Applies up to 40C				

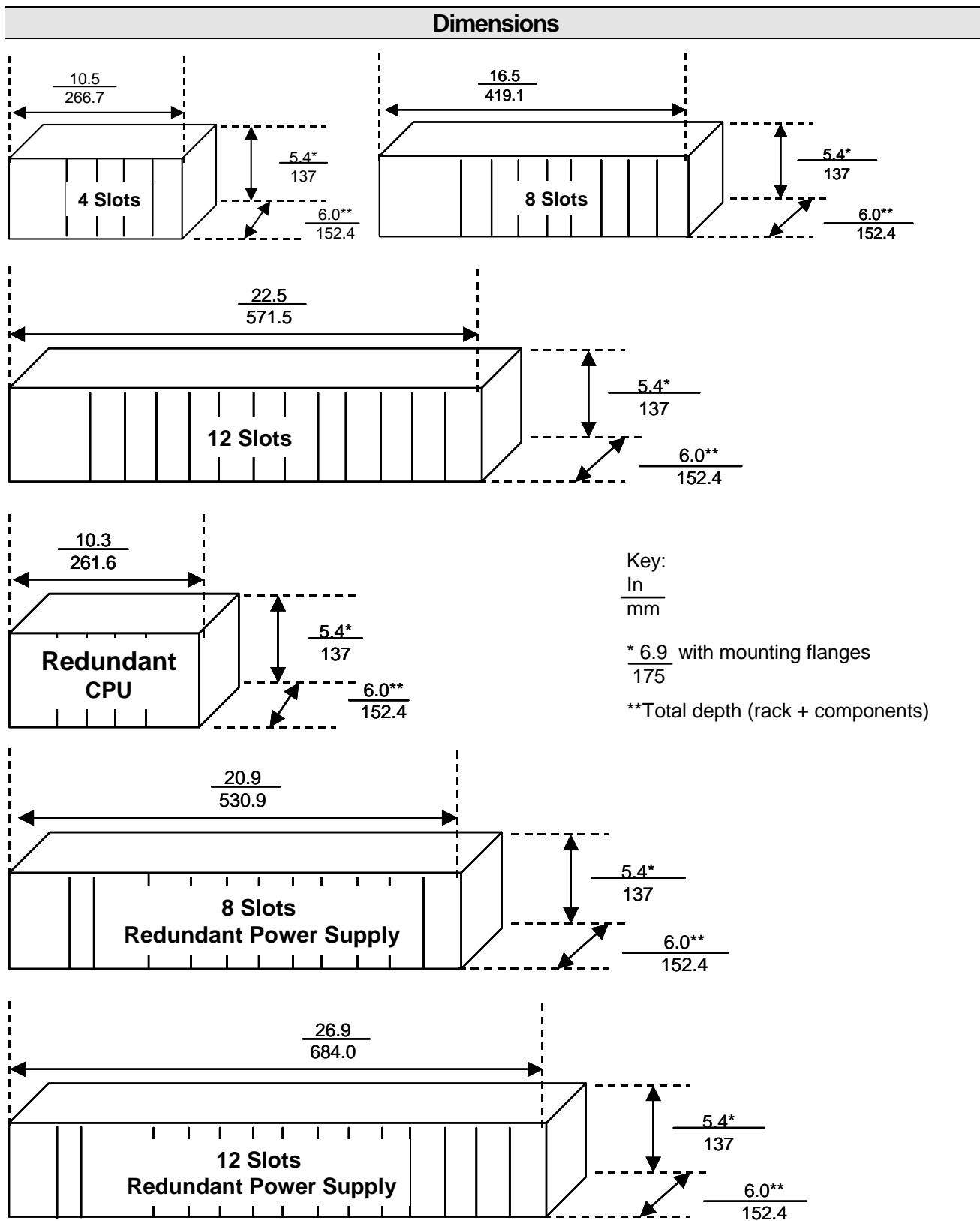

Figure 2 HC900 Hybrid Controller Dimensions

Warranty/Remedy

Honeywell warrants goods of its manufacture as being free of defective materials and faulty workmanship. Contact your local sales office for warranty information. If warranted goods are returned to Honeywell during the period of coverage, Honeywell will repair or replace without charge those items it finds defective. The foregoing is Buyer's sole remedy and is **in lieu of all other warranties, expressed or implied, including those of merchantability and fitness for a particular purpose**. Specifications may change without notice. The information we supply is believed to be accurate and reliable as of this printing. However, we assume no responsibility for its use.

While we provide application assistance personally, through our literature and the Honeywell web site, it is up to the customer to determine the suitability of the product in the application.

Distributor :

For more information, contact Honeywell sales at:
US: 1-800-343-0228
Canada: 1-800-461-0013

Honeywell

Industrial Measurement and Control
Honeywell
1100 Virginia Drive
Fort Washington, PA 19034